

SLATER'S WAGON KITS

M.R. 10T 16'6" COVERED GOODS WAGON AND VENTILATED FRUIT VAN.

Ref : Nos. 7mm Scale 7024 and 7024F

The M.R. 10T covered goods wagon and ventilated version cover a range of over 7866 vehicles plus a further 250 vehicles with end windows classed as tariff vans.

As the permutations are considerable modellers are recommended to consult MIDLAND WAGONS VOLS. 1 & 2 by R. J. ESSERY published by O.P.C. We are grateful for additional assistance that R. J. Essery and R. Betts have provided in the manufacture of these kits.

The basic variations are listed as follows. NOTE: that early batches built with grease boxes and brakes one side only would be rebuilt later in their lives with oil boxes and brakes both sides if still in service when this became mandatory, also the reference to some vehicles being fitted with automatic vacuum through pipes was a method whereby the vehicle could be marshalled in a complete train fitted with A.V.B. or Westinghouse without the actual vehicle being so fitted, the through pipe carrying the actual vacuum to vehicles marshalled behind the unfitted vehicle, from the locomotive.

Diagram 362.

Original batch first built 1893 fitted with grease axle boxes, 3' 2" dia. 8 spoke wheels. Brake gear one side only. Rated as 8 tons.

Tare
A.V.B. through pipe 5-14-0
A.V.B. + Westinghouse through pipe 5-15-0
Standard vehicle 5-12-0

Diagram 363

First built 1902 oil boxes 3' 2" dia wheels. Brake gear one side only when new. To carry 10 Tons.

Tare of wagons without through pipes 5-17-2
Tare with wagons fitted with AVB through pipes 5-19-0
Tare of wagons fitted with AVB and Westinghouse through pipe 6-0-0

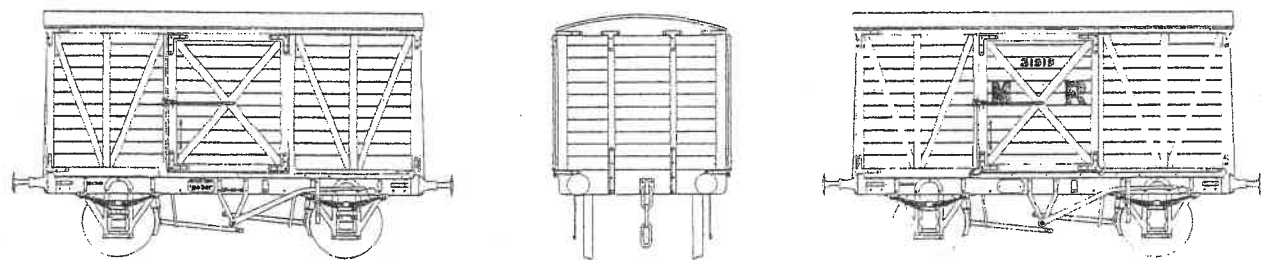

Diagram 362 Original livery as built. Used up to Mid 1890's.

Diagram 362 or 363 Livery style used from mid 1890's onwards.

Diagram 360

First built 1899. Grease axleboxes later batches built with oil boxes. 3' 7" dia. wheels 8 spoke fitted AVB and handbrake complete. Fitted with passenger type 'J' hangers and springs. rated to 5 Tons Passenger Train. 6 Tons Goods Train.

Tare 6-11-10

Note: Modellers should use the 'F' version and discard the louvres and torpedo vents.

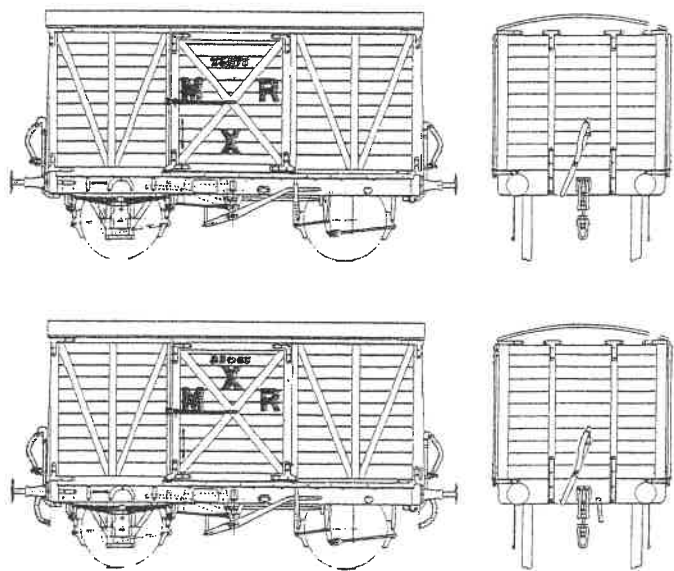

Diagram 360
Standard livery used throughout M.R. period for vehicles not fitted with steam heating.

Diagram 360
Standard livery style as used throughout M.R. period for SFV (Steam Fitted Vans).

NOTE
Steam heating pipes with couplings are available separately. Our ref. 7160

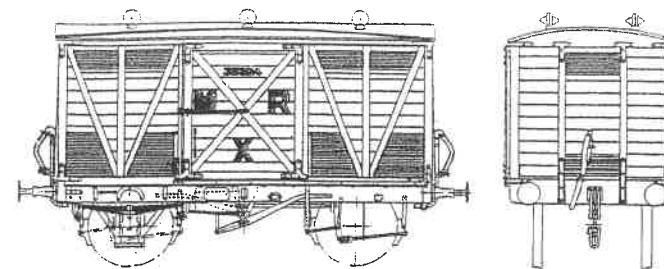

Diagram 361
Standard livery used throughout M.R. Period.

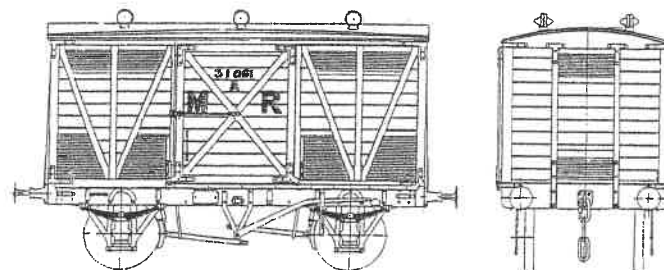

Diagram 364
Standard style used throughout the M.R. Period.

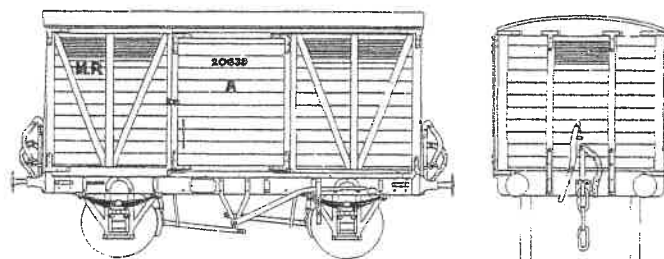
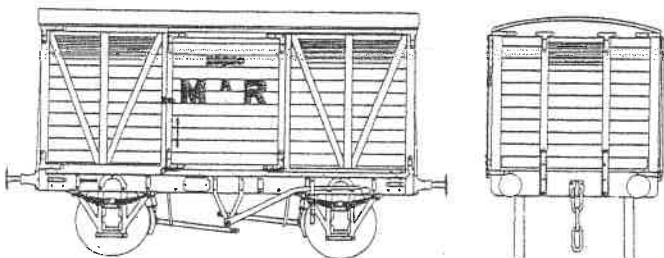
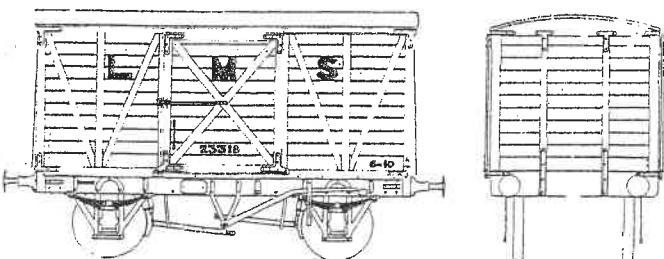

Diagram 378
Original style as built. This vehicle piped with vacuum and Westinghouse through pipes. The purpose of the Letter 'A' is unknown. However all photographs show vehicles built to Diagram 374 as having the Letter 'A' in both styles of lettering throughout the M.R. period.



Note: for LMS Period: From photographic evidence it appears that whilst vehicles were built with the standard M.R. short brake lever the majority of the vehicles were refitted with the long brake lever early in the LMS period.



Pre 1936 Lettering Style for all unfitted vehicles. Body and solebar colour LMS Wagon Grey ironwork below solebar Black.

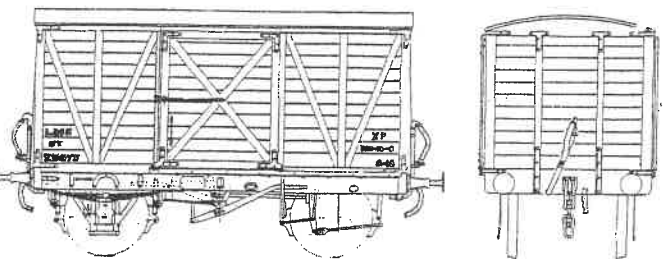

Post 1936 Lettering style for fitted and piped vehicles. For unfitted versions the XP and WB-10-0 in bottom righthand corner is omitted. Body colour LMS Bauxite.

LOUVRED VERSIONS

Diagram 361

Built 1903 to drawing no. 1822. Oil Boxes 3' 7" dia. 8 spoke wheels. Passenger type J. Hangers and springs. Fitted with automatic vacuum brake, screw link couplings. Tare 6-8-0.

Note: Drawing no. 1822 shows 3' 2" dia. wheels with wagon type springs. Whilst photographic evidence of vehicle No. 35324 shows the passenger type of suspension as detailed. Another case of variations built to the same drawing number.

Diagram 364

Built 1909 to drawing no. 1822. 3' 2" dia. wheels. Wagon type suspension oil boxes.

Tare of Wagons fitted with AVB through pipe 6-1-0 screw link couplings.
Tare of wagons without AVB through pipe 6-0-0 3 link couplings.

NOTE

Modellers should use the louvres and torpedo vents discarded when building vehicles to dia. 360.

Diagram 378

Built 1896 3' 2" dia. wheels, wagon type suspension, brakes one side only.

Grease axleboxes and 3 link couplings when new. Some were later fitted with oil boxes, brake gear both sides and screw link couplings.

Tare of Vans without through pipe 6-2-0
Tare of Vans with AVB + Westinghouse. 6-4-0

NOTE

The door supplied with this kit should be flushed over with a piece of scribed .020" Plastikard.

KNOWN VEHICLE NUMBERS

Diagram 362
114351 one of the original batch probably photographed 1893. Grease axleboxes brake gear one side only. No through pipes fitted 3 link couplings. Short rainstrip over door.
Note: The opening door numbers were the sliding type not the wheel type as supplied in the kit. It is probably that the door gear was changed in 1902 when drawing number 1642 was issued. Early batches would probably be altered at the same time as the grease boxes were changed for oil.

4197. Photographed in LMS grey livery. oil axleboxes, brake gear both sides 3 link couplings. No through pipes.
90766. Either Lot 658 or 695 photographed in LMS Bauxite April 1939 oil boxes fitted brake gear with sides. No through pipes 3 link couplings. Short rain strip over door. Tare 5-17-0.

90437. Lot 914 photographed September 1953. Oil boxes, brake gear both sides. No through pipes 3 link couplings. Short rain strip over door. Tare 5-16-0.

Diagrams 362 or 363 (No capacity visible).

3906. Photographed 1936. Oil boxes, brake gear both sides. No through pipe 3 link couplings. Tare 5-19-0.

23318. Photographed 1936. Oil boxes, brake gear both sides. No through pipe 3 link couplings. Tare 6-1-0.

31919. Photographed in B.R. Days. Oil boxes, brake gear both sides. No through pipes 3 link couplings. Tare 5-19-0.

47961. Preserved at Butterley. Oil boxes, brake gear both sides. No through pipes, 3 link couplings.

Diagram 360

60963, 85065 and 84883. Oil boxes, passenger type springs and 'J' hangers. 3' 7" dia. 8 spoke wheels. Screw link couplings. Fully fitted brake and steam heating pipes.

Note: The M.R. classed vans fitted with steam heating as special Fruit Vans (SFV) and numbers were recorded in the special wagon list for further numbers see O.P.C. Mid Wagons Vol. 2 page 22.

23675. Same specification as above except that it is not fitted for steam heating and therefore not classed as SFV.

Diagram 378

20639. Photographed as built. 3' 2" dia. wheels. Brakes one side grease boxes. Vacuum and Westinghouse through pipes, fitted 3 link couplings. These would be rebuilt with oil boxes and brake gear fitted both sides and screw link couplings in the early 1900's.

20850. Photographed 1920 fitted oil boxes.

28850. Photographed 1920 fitted oil boxes.

15764. Photographed 1948 fitted oil boxes vacuum through pipe and screw link coupling.

Note: This vehicle has been refitted with the standard type of door as per D360 - 363 and updated to 10 tons at same period.

Diagram 364

10761. 3' 2" dia. 8 spoke wheels. Oil boxes, torpedo vents. No letter 'A' on door. Full length rainstrip.

31091. 3' 2" dia. 8 spoke wheels. Oil boxes, torpedo vents. Full length rainstrip.

(Both vehicles were photographed in 1920).

Diagram 361

35324. Oil boxes fully fitted vacuum brake 3' 7" split spoke wheels screw link couplings. Torpedo vents. Full length rainstrip. Passenger type suspension and 'J' hangers.

Before beginning to assemble your model read the instructions carefully, and study the diagrams relating to the kit you are building. It is worth investing in a small sheet of plate glass on which to assemble your kit, as this will ensure that all components go together accurately and that all four wheels are level. Slater's MEK-PAK fluid cement is ideal for use with this kit, and will provide a clean and easy way for constructing your model. Remember that when using MEK-PAK the two components to be welded together must be in contact with each other before the MEK-PAK is applied to the joint with a paint brush. The MEK-PAK WILL FLOW OFF THE BRUSH INTO THE JOINT BY CAPILLARY ATTRACTION.

TRANSFERS — METHOD OF APPLICATION

The transfer sheet is composed of adhesive backed characters on a clear tissue carrier film, sandwiched to a paper backing film and protected by waxed tissue film.

Place the sheet on a flat surface with the tacky side uppermost. Cut round the required character with a sharp modelling knife, and carefully peel away from the backing sheet. Apply in position on your model with firm figure pressure, then rub over the back of the transfer with a biro or similar rounded instrument taking care that the transfer does not move during the process. When the whole area of the transfer has been rubbed down, wet the carrier film with water, wait for a few moments and then carefully peel off the carrier film from the transfer. Remove surplus water with absorbent tissue and proceed with the next character. For beginners it is a good idea to have some trial runs on a plain flat surface before attempting to letter a model, but once the basic technique of application has been grasped lettering becomes quick and simple.

To protect the lettering from damage and to give your model a realistic dull finish, coat it with a matt varnish (an aerosol such as Letracote 103 by Letraset is ideal).

IMPORTANT: When not in use the transfers should be kept in a polythene bag and stored in a cool dry place.

ASSEMBLY INSTRUCTIONS

1. Check all plastic components and etchings.

2. Assemble the sides and ends onto the floor. NOTE: That the location lugs on the inside of the ends sit on top of the floor. NEXT FIT THE solebars to the underside of the floor. The three locating lugs running lengthways along the floor are to locate the solebars and brake gear. The solebars fit on the outside of the lugs and the brake gear on the inside centre lug. (Do not fit the brake gear at this stage). The roof can now be fixed into position and the buffer bodies cemented into place using epoxy resin or permabond cyanacrylate (Our ref. 0801). At this stage the body can be sprayed either M.R. or LMS wagon grey if desired as the remainder of the components to be fitted are painted black.

3. Assemble the W irons solebar assemblies by carefully cutting out the etching from the fret. With a centre punch, punch out the two rivets in the keeper plate straps on each W iron. Next fold over the keeper plate straps the etch line being on the outside of the bend. IMPORTANT: THIS IS THE ONLY ETCHED CREASE LINE THAT IS ON THE OUTSIDE OF THE BEND. NOW FOLD UP THE REMAINDER OF THE W IRONS WITH THE CREASE on the inside of the bend. It is advisable to run a small fillet of solder along the inside of the crease to give additional strength once the assembly has been folded up. Next fit the bearings and wheels into the W irons and check that there is no side play in the bearings. NEXT lightly solder the bearings into position and check that the wheels turn freely. Finally assemble the moulded axleboxes on the W irons and fix the springs to the solebars remembering to leave sufficient clearance between the axlebox and springs so that the W iron can rock freely, and then locate onto the lugs on the underside of the floor making sure that the wheels sit square across the floor and that the W irons line up with the crown plates on the front of the solebars. The plastic lugs can be touched with a hot soldering iron to rivet the W irons to the floor.

4. Next fit the 3 link couplings. Due to the suspension system the coupling hook will foul the W iron assembly and should be shortened by 3/16" the existing slot in the hook should first be lengthened accordingly.

5. Fit the brake gear one side or both sides if later MR/LMS/BR periods are being modelled. Modellers building the fully fitted version should read the additional notes and study the appropriate drawing, and ignore instructions 6 & 7.

6. Fit the 'V' hangers. Two types are supplied in the kit the Large V is for the Cheshire Lines Committee Version.

7. Fit brake levers, short for M.R. long for later LMS/BR and Cheshire Line Vehicles.

8. Fit doors, handles and other fine details.

9. ADDITIONAL INSTRUCTIONS FOR ASSEMBLING THE FULLY FITTED FRUIT VAN VERSIONS.

Because this kit is basically a fitted version of the standard 10T covered wagon with the addition of vacuum brakes, torpedo vents and louveres, there are certain parts of the standard 7024 kit which will not be required for this kit and should be discarded. They are all contained on the solebar fret. ONLY the solebar and brake ratchet will be required from this fret.

In addition if modellers wish to build this kit to Dig 360 the louveres and torpedo vents will not be needed, however they can be used to convert the standard kit (7024) into a Diagram 364 version. Modellers should note that we have included AN EXTRA 'V' hanger marked A. WHILST THIS IS NOT needed for this kit it is possible with some modifications and a little scratch building to build BANANA VANS to diagram 387 and vehicles built to this diagram did not have the extra cam fitted to the V hanger (Marked B) to enable the brake levers to point to the right of the vehicle when viewed from both sides with the result that one brake lever pointed to the left hand side of the vehicle i.e. both levers pointed to the same end of the vehicle.

ADDITIONAL INSTRUCTIONS FOR ASSEMBLING THE BRAKE GEAR ON THE 7mm M.R. FITTED COVERED GOODS WAGON.

Cut out the suspension unit (3) and fold up the two rocking lugs fitting them through the two outermost slots on the bridging piece of the W iron No. 1 and twist the lugs to lock the rocking unit onto the W iron.

Ensure that W iron will rock freely on its base plate.

NOW cut out the brake shoe hangers (4) and fold up into a 'U' shape fitting the moulded brake shoe between the two 'arms' of the 'U'.

A small piece of 020 plastic rod pushed through the assembly and cut to length will locate the brake shoes. A light dab of MEK-PAK with a fine brush will lock the rod to the shoe so that the brake shoe will now rock between the brake hangers. NOTE that the brake shoes are right and left handed (see the insert drawing). Cut out parts 6 & 12 and solder into the etched slots across the base of the 'W' irons Part No. 6 with one locating lug locks into the remaining centre slot on W iron No. 1, No. 12 with 2 lugs fits into W iron No. 2. Next solder the brake hangers to the base of the 'W' irons the small tag on Part No's 4 locate into the small slots in the corners of the 'W' iron bases. The brake drag beams should be fitted next (13,7,14,5). They are fitted into each W iron assembly as pairs (13 & 14) and (7 & 5). The two base points of each leg locking into the centre hole of the brake shoes with the drag rods pointing into the centre of the assembly. The drag rods with the adjuster plate clip onto the small tag on parts No 6 & 13 viewed when the vehicle is in the normal upright position. All later references to the position of linkages will use the same vehicle position. The two drag rods attached to drag beams 13 & 7 now clip into the lower holes of Parts 6 & 13. The complete W iron assemblies should now be fitted to the lugs on the underside of the floor. It is important that the assemblies should be mounted the correct way round so that the pull rods (8 & 11) from the brake cylinder will reach the drag beam pivots (6 & 13). Reference to the side elevation drawing should make this clear.

FIT THE 'V' HANGERS.

The hanger with the extra cam should be mounted on the side nearest to the brake cylinder using the moulded shaft fitted between the two V hangers (A & B) after first fitting on Part No. 10 & 13. Part No. 13 should be on the side nearest to the brake cylinder. Part No. 10 is in the centre of the rod.

Rivet Part No. 9 to the small hole on Part 10 using the centre hole in 9, the two pull rods 11 & 8 connect to the two other holes on 9.

FOLD UP Part 16 and fit the etched portion over the small hole on 15 rivetting into position using .020 rod. The other end of 16 should be bent out to form a 'U' which fits over the cylinder spindle. Finally fit the brake levers note that when viewed from the side the brake lever handles should be on the right of the vehicle. Remember that the lever nearest the cylinder should be mounted on the top of the small cam above the main brake rod.

Finally fit vacuum pipes. The connectors on the ends of the hose are to enable the hose to be connected to the next vehicle. As the spring hose is delicate care should be exercised when coupling and uncoupling. DO NOT attempt to part the couplings by pulling the springs. The two couplings should be prised apart.

